



USER MANUAL

Timing lock kit PSA, BMW 1.4/1.6 Petrol QS10324



26/01

PRODUCT DESCRIPTION

Complete timing service kit, allowing you to replace and check the timing in 1.4 and 1.6 PSA/BMW engines. Supported engine codes are BMW and MINI: N12, N13, N14, N16 and N18 and Citroën/Peugeot: EP3 and EP6. The kit includes a digital protractor (inclinometer) recommended by PSA to check chain wear and correct positioning of the intake shaft of variable valve timing.

Application:

- CITROEN:** Berlingo III (09-18), C3, C3 Picasso (09-15), C4, C4 Picasso (08-19), C5 III (09-15), DS3, DS3 Convertible (09-17), DS4 (11-15), DS5 (12-15)
- PEUGEOT:** 207, 207 CC (06-16), 208 (12-19), 308, 308CC (07-19), 508 (11-18), 2008 (13-17), 3008 (09-), 5008 (09-), Partner (09-18), RCZ (10-16)
- DS:** 3 (15-19), 4 (15-19), 5 (15-18), 7 Crossback (17-)
- BMW:** Series 1 (11-16), Series 3 (12-15)
- MINI:** Mini (06-15), Clubman (07-14), Countryman (10-17), Coupe (11-15), Roadster (12-15), Paceman (13-17)

Engine codes:

- 1.4 – N12 B14A
- 1.4 Vti – 8FN (EP3C), 8FP (EP3C), 8FR (EP3C), 8FS (EP3)
- 1.6 – N13 B16A, N14 B16A, N14 B16C, N16 B16A, N18 B16A, N18 B16C
- 1.6 Vti – 5FK (EP6CB), 5FL (EP6C), 5FP (EP6), 5FS (EP6C), 5FW (EP6), EP6 (5FW), EP6C (5FH), EP6C (5FK), EP6C (5FS)
- 1.6 THP – 5FD (EP6DTS), 5FE (EP6CDTM), 5FF (EP6DTS), 5FM (EP6CDTM), 5FN (EP6CDT), 5FR (EP6DTE), 5FT (EP6DT), 5FU (EP6CDTX), 5FV (EP6CDT), 5FX (EP6DT), 5GM (EP6FDTX), 5GR (EP6FDTX), 5GT (EP6FDTX), 5GW (EP6FDT), 5GY (EP6FDT), 5GY (EP6FDTM), 5GZ (EP6FDT), EP6CDT (5FA), EP6CDT (5FE), EP6CDT (5FM), EP6CDT (5FN), EP6CDT (5FV), EP6CDTR (5FG), EP6CDTX (5FU), EP6DT (5FT), EP6DT (5FX), EP6DTE (5FR), EP6DTS (5FY), EP6FDT (5GW), EP6FDT (5GZ), EP6FDTM (5GY), EP6FDTR (5GN), EP6FDTR (5GP), EP6FDTX (5GR), EP6FDTX (5GT)
- 1.6 PureTech – 5GY (EP6FADTXD), 5GF (EP6FADTX), 5GG (EP6FADTX)

Kit contents:

- A – Exhaust camshaft lock | OEM: 0197-A1/A1Z, 0197-A11, 11 7 440, 11 9 551, 11 9 540
- B – Intake camshaft lock | OEM: 0197-A2, 11 9 551
- C – M10 Screw
- D – Intake camshaft lock | OEM: 0197-A3, 0197-031, 11 7 440, 11 9 540
- E – Crankshaft locking pin | OEM: 0197-BZ, 11 9 590, 49 6 709, 2 299 362
- F – M5 Screws (6 pcs)
- G – Camshaft Exhaust Lock Adapter | OEM: 0197-A1/AZ, 11 7 440, 11 9 540
- H – A&B Connector | OEM: All Cam Assemblies
- I – Intake camshaft lock adapter | OEM: 0197-A2, 11 9 551
- J – Intake Camshaft Lock Adapter | OEM: 0197-A31, 11 7 440
- K – Camshaft Exhaust Lock Adapter | OEM: 0197-A11, 11 9 551, 11 9 440
- L – Intake Camshaft Lock Adapter | OEM: 0197-A3, 11 9 540
- M – Digital Protractor (Inclinometer) | OEM: G-1376-A
- N – Timing Chain Tensioner | OEM: 0197-M, 11 9 340
- O – Digital Protractor Angle | OEM: E1.100

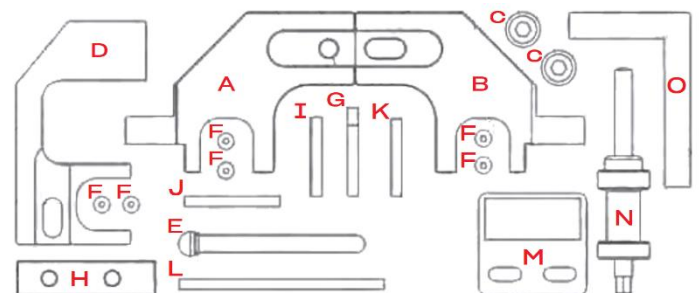

Auxiliary information on how to combine individual kit components to obtain a specific OEM tool:

PSA OEM 0197-A1/A1Z – Camshaft Exhaust Locking
Tool Kit: A+G

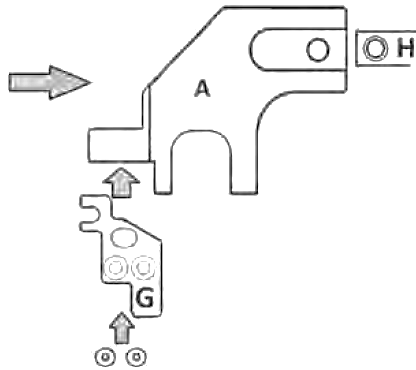

PSA OEM 0197-A11 – Exhaust Camshaft Locking Tool Kit: A+K

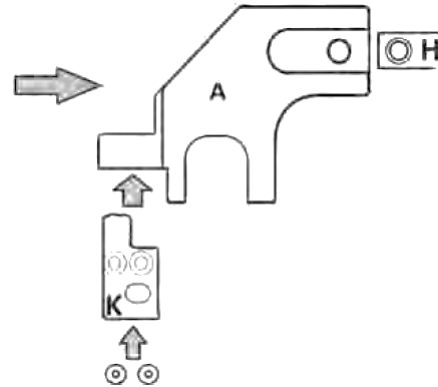

PSA OEM 0197-A2 – Camshaft Intake Locking Tool
Kit: B+I

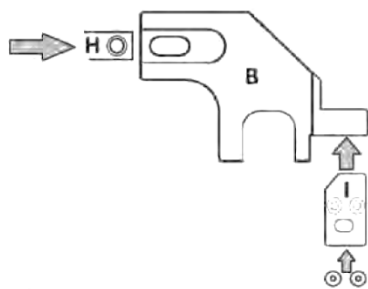

BMW OEM 11 7 440 – Camshaft Locking Tool Kit: A+K+H+D+J

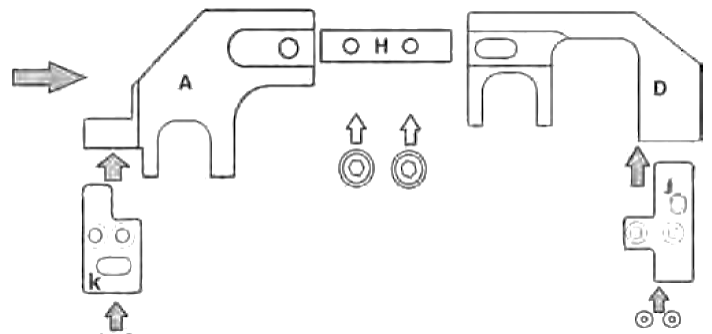

PSA OEM 0197-A3 – Camshaft Suction Locking Tool
Kit: D+L

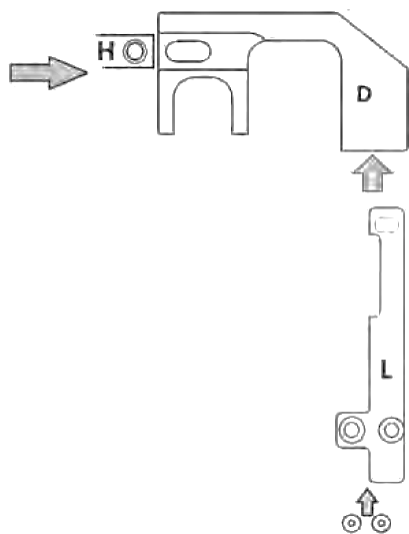

BMW OEM 11 9 551 – Camshaft Locking Tool Kit: A+K+H+B+I

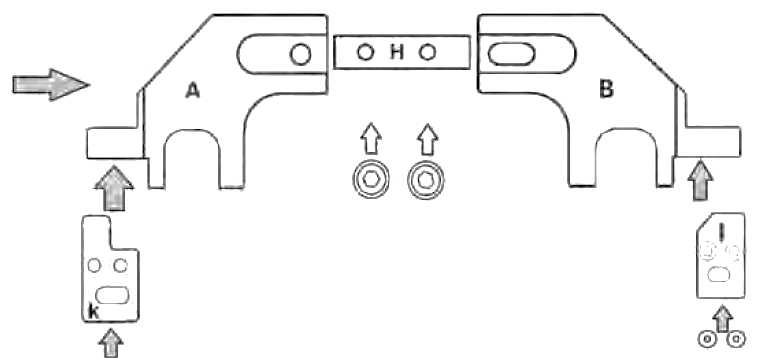

PSA OEM 0197-A31 – Intake Camshaft Locking Tool
Kit: D+J

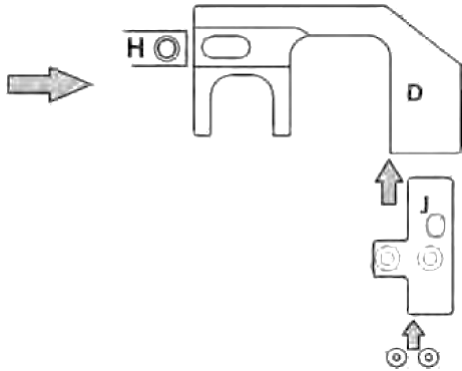

BMW OEM 11 9 540 – Camshaft Locking Tool Kit: A+G+H+D+L

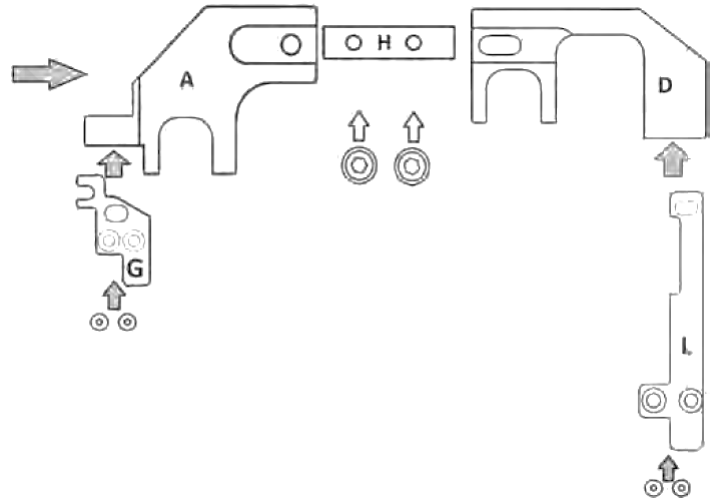

SAFETY RULES

 NOTE: The product contains a battery

Battery Type: AAA
Type: Alkaline Battery
Voltage: 1.5V



GENERAL AAA BATTERY SAFETY WARNINGS

- Use AAA batteries only in devices designed for this purpose, making sure that the polarity (+ and -) is correct.
- Never attempt to charge disposable (alkaline) batteries. This may result in leakage, fire or explosion.
- Do not disassemble, crush, puncture, or otherwise damage the battery. This can lead to chemical leakage or fire.
- Do not expose batteries to high temperatures (e.g. direct sunlight) or dispose of them in a fire.

LEAKAGE AND SHORT CIRCUIT WARNINGS

- Do not short-circuit the battery terminals (do not connect + and - with metal objects). This may result in heat generation, fire or explosion. Store batteries in their original packaging or containers, away from metal objects.
- If you notice a battery leak, remove it from the device immediately (using protective gloves). Avoid contact with any leaking substance that may be corrosive. In case of contact with skin or eyes, rinse immediately with plenty of water and consult a doctor.

WARNINGS FOR CHILDREN AND SWALLOWING

- Batteries, especially small AAA batteries, should be kept out of the reach of small children.
- Swallowing batteries is life-threatening. If swallowed, seek medical attention immediately and contact a poison center.

DEALING WITH USED BATTERIES

According to Regulation 2023/1542, batteries must be collected selectively. Improper disposal can harm the environment and health.

- Never dispose of used AAA batteries in a regular trash can. These batteries must be collected selectively.
- Return used batteries to designated collection points (shops, recycling points, containers in public buildings) or to a retailer.

USER MANUAL

The timing lock kit is only used to lock it in a specific position when setting the timing mechanism. It is forbidden to use any component of the kit to immobilize any of the engine components in order to re/tighten threaded connections, e.g. from/tightening gears. This can lead to permanent damage to the timing lock kit and also cause damage to engine components.

Electronic Protractor Instruction Manual**Specifications**

Scope of work	4 x 90°
Accuracy	0° and 90°: ± 0.1° (other: ± 0.2°)
Operating Temperature	0°C - 40°C
Power supply	1 x AAA 1.5V battery

Button functions**ON/OFF**

- To switch on the device, press the ON/OFF button once. To turn off the device, hold down the ON/OFF button for 2 seconds. The appliance will turn off automatically after 5 minutes. To restart the device, press the ON/OFF button once.
- When the protractor is already running (and is not in the absolute angle measurement mode), pressing the ON/OFF button once switches the device's operating mode to the absolute angle measurement mode (the ABS icon will appear on the display) – the protractor behaves like a spirit level, treating 0.0° as the proper level.

ZERO

- When the protractor is already running (and is not in the relative angle measurement mode), setting the protractor on the selected plane and pressing the ZERO button once switches the device's operating mode to the relative angle measurement mode (the ABS icon disappears) – the protractor relates the measurements to the plane on which it was zeroed.

Calibration

Important: The protractor has been pre-calibrated at the factory. The product should only be recalibrated if necessary.

1. Place the protractor on a flat surface.
2. Press the ON/OFF button and the ZERO button at the same time – "-1-" will appear on the display.
3. Press the ON/OFF button – "-1-" will flash. Wait for "-2-" to appear on the display.
4. Press the ON/OFF button – "-2-" will flash. Wait for the device to finish calibrating.

Battery Replacement

1. Make sure the protractor is turned off.
2. Remove the battery cover.
3. Remove the used battery and install a new one, paying attention to its polarity.
4. Install the battery cover.

Determining the Camshaft Correction Angle

1. Position the engine timing in the correct position, making sure that the camshafts are in the correct position – their flat locating (milling) surfaces are in the position shown in the figure. Then insert the crankshaft locking pin (E).

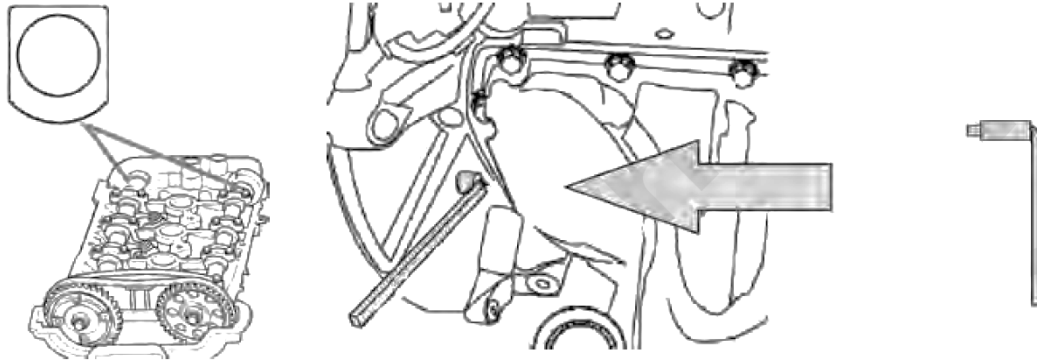

2. Use the inclinometer (M) and the angle (O) to check the chain extension according to the OEM specification (PSA). Place the (M) and (O) elements on the cylinder head as shown in the figure and zero the inclinometer (M). Place the (M) and (O) elements on the retaining surface of the intake camshaft and record the displayed value. Repeat the same process for the exhaust camshaft retaining surface and also record the reading. *NOTE: The arrows displayed on the protractor indicate the direction in which the 0.0° or 90.0° level is, so always write down the reading direction – up arrow (▲) = negative angle, down arrow (▼) = positive angle.* Compare the readings with the manufacturer's data.

Final timing setup

Once the correction angle has been determined, the protractor on each of the camshaft setting surfaces should be zeroed and then adjusted by the calculated correction angle.

- Insert the ampoule wrench H6 through the center of the intake camshaft and adjust the position of the shaft until the protractor indicates the calculated angle.
- Repeat the same procedure for the exhaust camshaft.
- Once the camshafts are in the correct position and locked, tighten the camshaft wheels to 20 Nm.

For example:

WARNING: The following values are for reference only. Please refer to the tolerances for your engine as specified by your vehicle manufacturer or in Autodata.

DADA engine code (1.5 L) – manufacturer's recommendations:

- Correct angle for intake camshaft: $-0.3^\circ (+/- 1.2^\circ)$ = range from -1.5° (▲) to $+0.9^\circ$ (▼)
 measured angle: (▲ 0.9°), which is $-0.9^\circ \rightarrow (-0.3^\circ) - (-0.9^\circ) = -0.3^\circ + 0.9^\circ = 0.6^\circ$
Conclusion: The intake camshaft should be turned clockwise with the H6 key by a clockwise angle of 0.6°
- Correct Camshaft Exhaust Angle: $+1.1^\circ (+/- 1.2^\circ)$ = Range from -0.1° (▲) to $+2.3^\circ$ (▼)
 measured angle: (▲ 1.0°), i.e. $-1.0^\circ \rightarrow (+1.1^\circ) - (-1.0^\circ) = 1.1^\circ + 1.0^\circ = 2.1^\circ$
Conclusion: The exhaust camshaft should be turned clockwise with the H6 key

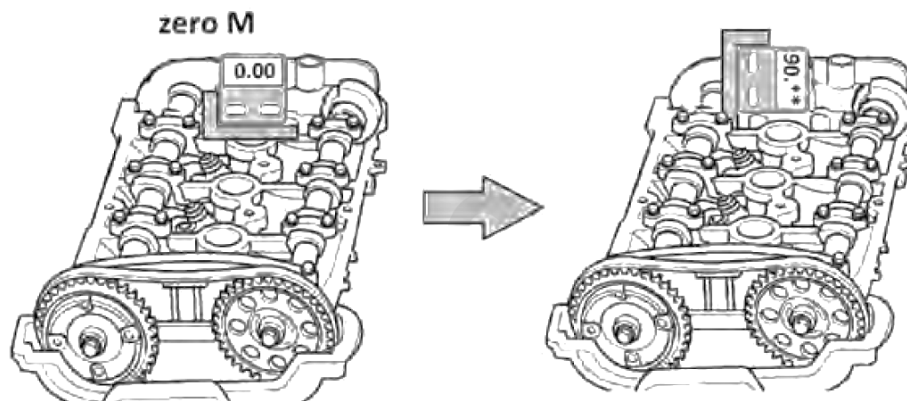

3. Lock both camshafts using A+B or A+D components, using the appropriate retaining adapters, according to the required OEM part numbers. *NOTE: The camshaft locking elements must be installed so that the connecting strip (H) is facing the engine gearbox.*

WARRANTY CONDITIONS

1. TECHSAM warrants the proper operation of the product for a period of 12 months from the date of purchase.
2. The warranty includes free removal of defects and factory defects revealed during the warranty period.
3. The warranty does not cover mechanical damage or damage caused by improper use of the product.
4. The warranty expires if repairs or alterations are found by unauthorized persons.
5. The condition for considering the warranty is the presentation of the warranty card together with the complained product at the service point or at the point of sale.
6. The warranty is valid only with the seller's stamp and the date of sale.
7. Warranty and post-warranty service is provided by the importer.

P.W. TECHSAM WOCH Sp. J.
al. Warszawska 131
20-824 Lublin
tel. +48 81 444 63 73
E-mail: techsam@quatros.pl

Date of sale

Seller's signature and seal

 In accordance with the European Union Directive No. 2002/96/EC and the Polish Act on Waste Electrical and Electronic Equipment (Journal of Laws of 2005 No. 180, item 1495), any equipment marked with the "crossed-out waste bin" stamp after its service life cannot be placed with other waste, but must be recycled. Details on www.quartos.pl



Lublin, 22.01.2026

DECLARATION OF CONFORMITY

PW TECHSAM WOCH SP. J.
131 Warszawska Avenue
20-824 Lublin

Declares that the product:

Timing lock kit
PSA, BMW 1.4/1.6 Petrol
QUATROS QS10324

It complies with the following standards:

EN 61326-1: 2013

EN 301 489-1 V2.2.3; EN 301 489-17 V3.2.4

EN 300 328 V2.2.2; EN 62479:2010

and is identical to the unit assessed by:

SGS-CSTC Standards Technical Services Co.,Ltd. Guangzhou Branch

No. 198, Kezhu Road, Science City, Economic & Technological Development Area, Guangzhou, China, 510663

tel +86 (0) 20 82155555

fax +86 (0) 20 82075059; +86 (0)20 8207 5058

E-mail: ee.guangzhou@sgs.com

Certificate No.: GZCR2107020675HSV

Technical Construction File (TCF) no:

GZCR210702067501, GZCR210702067502, GZCR210702067503, GZCR210702067504

In the event of any modifications to the device, this declaration shall be invalid.

A person authorized to prepare technical documentation:

Marcin Puderecki
(name)



(podpis)